



## PRODUCT SPECIFICATION

# 6252BA-SR

**Wi-Fi Dual-band 2x2 11ax + Bluetooth 5.2**

**Combo Module**

Version:v1.5

**Customer:** \_\_\_\_\_

**Customer P/N:** \_\_\_\_\_

**Signature:** \_\_\_\_\_

**Date:** \_\_\_\_\_

Office: 14th floor, Block B, phoenix zhigu, Xixiang Street, Baoan District, Shenzhen

Factory: NO.8, Litong RD., Liuyang Economic & Technical Development Zone, Changsha, CHINA

TEL:+86-755-2955-8186

Website:www.fn-link.com

# 6252BA-SR Module Datasheet

Ordering Information	Part NO.	Description
	FG6252BASR-00	RTL8852BS, a/b/g/n/ac/ax Wi-Fi, 2T2R, BT5.2,13*15mm, SDIO,UART,Dual antenna (PIN AP6275S)

Target power:

2.4G: 19/18/17/13

5G: 18/17/15/13

## CONTENTS

<b>1. General Description .....</b>	<b>5</b>
1.1 Introduction .....	5
1.2 Description .....	5
<b>2. Features .....</b>	<b>6</b>
<b>3. Block Diagram .....</b>	<b>7</b>
<b>4. General Specification .....</b>	<b>7</b>
4.1 WI-FI 2.4GHz Specification .....	7
4.2 WI-FI 5GHz Specification .....	8
4.3 Bluetooth Specification .....	10
<b>5. ID setting information .....</b>	<b>11</b>
<b>6. Pin Definition .....</b>	<b>11</b>
6.1 Pin Outline .....	11
6.2 Pin Definition details .....	12
<b>7. Electrical Specifications .....</b>	<b>14</b>
7.1 Power Supply DC Characteristics .....	14
7.2 Interface Circuit time series .....	14
7.2.1 Power on sequence .....	14
7.2.2 SDIO Pin Description .....	15
7.2.3 SDIO Timing Diagram .....	15
<b>8. Size reference .....</b>	<b>16</b>
8.1 Module Picture .....	16
8.2 Marking Description .....	16
8.3 Physical Dimensions .....	17
8.4 Layout Recommendation .....	18
<b>9. The Key Material List .....</b>	<b>18</b>
<b>10. Reference Design .....</b>	<b>19</b>
<b>11. Recommended Reflow Profile .....</b>	<b>19</b>
<b>12. Package .....</b>	<b>20</b>
12.1 Reel .....	20
12.2 Carrier Tape Detail .....	21
12.3 Packaging Detail .....	21
12.4 Tray .....	22
<b>13. Moisture sensitivity .....</b>	<b>22</b>



# 1. General Description

## 1.1 Introduction

6252BA-SR is a low-cost and low-power consumption module which has all of the Wi-Fi functionalities. It is a highly-integrated IEEE 802.11 a/b/g/n/ac/ax MAC/Baseband/RF WLAN single chip. For Wireless LAN operation. The integrated module provides SDIO 3.0 interface for Wi-Fi. The module provides simple legacy and 20MHz/40MHz/80MHz co-existence mechanism to ensure backward and network compatibility.

The wireless module complies with IEEE 802.11 a/b/g/n/ac/ax 2x2 MIMO standard and the speed can achieve up to 1201Mbps with dual stream in 802.11ax. The integrated module provides SDIO interface for Wi-Fi, UART / PCM interface for Bluetooth.

This combo module is a total solution for a combination of Wi-Fi and Bluetooth V5.2 technologies. The module is specifically developed for all portable devices.

## 1.2 Description

Model Name	6252BA-SR
Product Description	Support Wi-Fi/Bluetooth functionalities
Dimension	L x W x H: 15 x 13 x 2.35 mm
Wi-Fi Interface	Support SDIO V1.0/V2.0/V3.0
BT Interface	UART / PCM
OS supported	Android /Linux/iOS /WIN10
Operating temperature	0°C to 70°C
Storage temperature	-40°C to 85°C

## 2. Features

### General Features

- Highly integrated wireless local area network (WLAN) system-on-chip (SOC) for 802.11a/b/g/n/ac/ax WLAN applications
- Supports Dual band Single concurrent (2.4G/5G).
- Dual-stream spatial multiplexing up to 1201 Mbps data rate.
- Supports 20/40MHz at 2.4GHz and supports 20/40/80MHz at 5GHz
- Supports Transmit Beamforming

### Host Interface

- Supports low power SDIO3.0(complies with SDIO 1.1/2.0) interface for WLAN and UART/PCM interface for Bluetooth.

### Bluetooth Features

- Supports Bluetooth system (BT5.2 Logo Compliant)
- Supports WLAN/Bluetooth coexistence
- Compatible with Bluetooth v2.1+EDR.
- Dual Mode support: Simultaneous LE and BR/EDR
- BT host digital interface:
  - HCI UART
  - PCM for audio data

### 3. Block Diagram

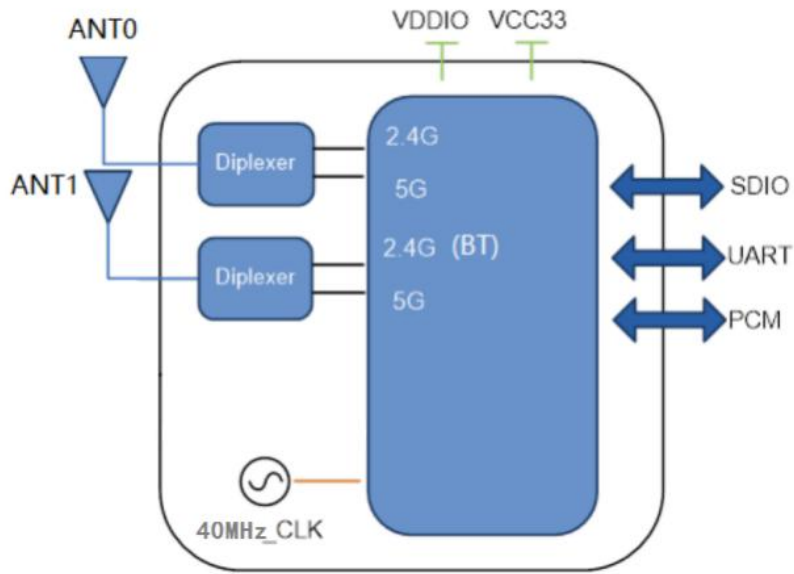

### 4. General Specification

#### 4.1 WI-FI 2.4GHz Specification

Feature	Description		
WLAN Standard	IEEE 802.11 b/g/n/ax Wi-Fi compliant		
Frequency Range	2.400 GHz ~ 2.4835 GHz (2.4 GHz ISM Band)		
Number of Channels	2.4GHz: Ch1 ~ Ch14		
Test Items	Typical Value		EVM
Output Power <sup>1</sup>	802.11b /11Mbps	19dBm ± 2 dB	EVM ≤ -10dB
	802.11g /54Mbps	18dBm ± 2 dB	EVM ≤ -25dB
	802.11n /MCS7	17dBm ± 2 dB	EVM ≤ -28dB
	802.11ax HE20 MCS11	13dBm ± 2 dB	EVM ≤ -35dB
	802.11ax HE40 MCS11	13dBm ± 2 dB	EVM ≤ -35dB
Spectrum Mask	Meet with IEEE standard		
Freq. Tolerance	± 20ppm		
SISO Receive Sensitivity (11b,20MHz) @8% PER	- 1Mbps	PER @ -94 dBm	≤-83
	- 11Mbps	PER @ -85 dBm	≤-76
SISO Receive Sensitivity (11g,20MHz) @10% PER	- 6Mbps	PER @ -90 dBm	≤-85
	- 54Mbps	PER @ -71 dBm	≤-68
SISO Receive Sensitivity	- MCS=0	PER @ -90 dBm	≤-85

(11n,20MHz) @10% PER	- MCS=7	PER @ -69 dBm	≤-67
SISO Receive Sensitivity	- MCS=0	PER @ -87 dBm	≤-82
(11n,40MHz) @10% PER	- MCS=7	PER @ -66 dBm	≤-64
SISO Receive Sensitivity	- MCS=0	PER @ -90 dBm	≤-74
(11ax,20MHz) @10% PER	- MCS=11	PER @ -60 dBm	≤-52
SISO Receive Sensitivity	- MCS=0	PER @ -87 dBm	≤-71
(11ax ,40MHz) @10% PER	- MCS=11	PER @ -57 dBm	≤-49
Maximum Input Level	802.11b : -10 dBm		
	802.11g/n : -20 dBm		
Antenna Reference	Small antennas with 0~2 dBi peak gain		

## 4.2 WI-FI 5GHz Specification

Feature	Description		
WLAN Standard	IEEE 802.11a/n/ac/ax, Wi-Fi compliant		
Frequency Range	5.15 GHz ~ 5.850 GHz(5.0 GHz ISM Band)		
Test Items	Typical Value	EVM	
Output Power <sup>1</sup>	802.11a /54Mbps:	18 dBm ± 2 dB	EVM ≤ -25dB
	802.11n /MCS7:	17 dBm ± 2 dB	EVM ≤ -28dB
	802.11ac vHT20 MCS8:	16 dBm ± 2 dB	EVM ≤ -30dB
	802.11ac vHT40 MCS9:	15 dBm ± 2 dB	EVM ≤ -32dB
	802.11ac vHT80 MCS9:	15 dBm ± 2 dB	EVM ≤ -32dB
	802.11ax HE20 MCS11:	13 dBm ± 2 dB	EVM ≤ -35dB
	802.11ax HE40 MCS11:	13 dBm ± 2 dB	EVM ≤ -35dB
802.11ax HE80 MCS11:	13 dBm ± 2 dB	EVM ≤ -35dB	
Spectrum Mask	Meet with IEEE standard		
Freq. Tolerance	± 20ppm		
SISO Receive Sensitivity	- 6Mbps	PER @ -90 dBm	≤-85
(11a,20MHz) @10% PER	- 54Mbps	PER @ -71 dBm	≤-68
SISO Receive Sensitivity	- MCS=0	PER @ -90 dBm	≤-85
(11n,20MHz) @10% PER	- MCS=7	PER @ -69 dBm	≤-67
SISO Receive Sensitivity	- MCS=0	PER @ -87 dBm	≤-82
(11n,40MHz) @10% PER	- MCS=7	PER @ -66 dBm	≤-64
SISO Receive Sensitivity	- MCS=0, NSS1	PER @ -90 dBm	≤ -82
(11ac,20MHz) @10% PER	- MCS=8, NSS1	PER @ -66 dBm	≤ -60
SISO Receive Sensitivity	- MCS=0, NSS1	PER @ -87 dBm	≤ -79

(11ac ,40MHz) @10% PER	- MCS=9, NSS1 PER @ -59 dBm	≤ -55
SISO Receive Sensitivity	- MCS=0, NSS1 PER @ -84 dBm	≤ -79
(11ac,80MHz) @10% PER	- MCS=9, NSS1 PER @ -56 dBm	≤ -54
SISO Receive Sensitivity	- MCS=0 PER @ -90 dBm	≤ -74
(11ax,20MHz) @10% PER	- MCS=11 PER @ -60 dBm	≤ -52
SISO Receive Sensitivity	- MCS=0 PER @ -87 dBm	≤ -71
(11ax ,40MHz) @10% PER	- MCS=11 PER @ -57 dBm	≤ -49
SISO Receive Sensitivity	- MCS=0 PER @ -84 dBm	≤ -68
(11ax,80MHz) @10% PER	- MCS=11 PER @ -54 dBm	≤ -46
Maximum Input Level	802.11a/n: -30 dBm	
Antenna Reference	Small antennas with 0~2 dBi peak gain	

2. 2.4G,5G output power control by firmware power by rate table, the table value must same with module target power

**15GHz(20MHz) Channel table**

<b>Band range</b>	<b>Operating Channel Numbers</b>	<b>Channel center frequencies(MHz)</b>
5150MHz~5250MHz	36	5180
	40	5200
	44	5220
	48	5240
5250MHz~5350MHz	52	5260
	56	5280
	60	5300
	64	5320
5470MHz~5725MHz	100	5500
	104	5520
	108	5540
	112	5560
	116	5580
	120	5600
	124	5620
	128	5640
	132	5660
	136	5680
5725MHz~5850MHz	140	5700
	149	5745
	153	5765

	157	5785
	161	5805
	165	5825

Note: The Wi-Fi RF specification data will be updated in future version.

### 4.3 Bluetooth Specification

Feature	Description
<b>General Specification</b>	
Bluetooth Standard	BDR(1Mbps),EDR(2Mbps & 3Mbps),LE(1Mbps),2LE(2Mbps)
Host Interface	UART
Frequency Band	2400 MHz ~ 2483.5 MHz
Number of Channels	79 channels for classic,40 channels for BLE
Modulation	GFSK, $\pi/4$ -DQPSK,8DPSK
<b>RF Specification</b>	
<b>Output Power , tolerance <math>\pm 3</math> dB</b>	
	<b>CL1(dBm)</b>
BDR Output Power	5
EDR Output Power	5
BLE Output Power	5
<b>Sensitivity, tolerance : /</b>	
Sensitivity @ BER=0.1% for GFSK (1Mbps)	-92
Sensitivity @ BER=0.01% for $\pi/4$ -DQPSK (2Mbps)	-86
Sensitivity @ BER=0.01% for 8DPSK (3Mbps)	-85
Sensitivity @ BLE=30.8% for LE (1Mbps)	-90
Sensitivity @ BLE=30.8% for 2LE (2Mbps)	-90

Maximum Input Level	GFSK (1Mbps):-20dBm
	$\pi/4$ -DQPSK (2Mbps) :-20dBm
	8DPSK (3Mbps) :-20dBm

Note: The Bluetooth Specification will be updated in future version.

## 5. ID setting information

WI-FI

Vendor ID	TBD
Product ID	TBD

## 6. Pin Definition

### 6.1 Pin Outline

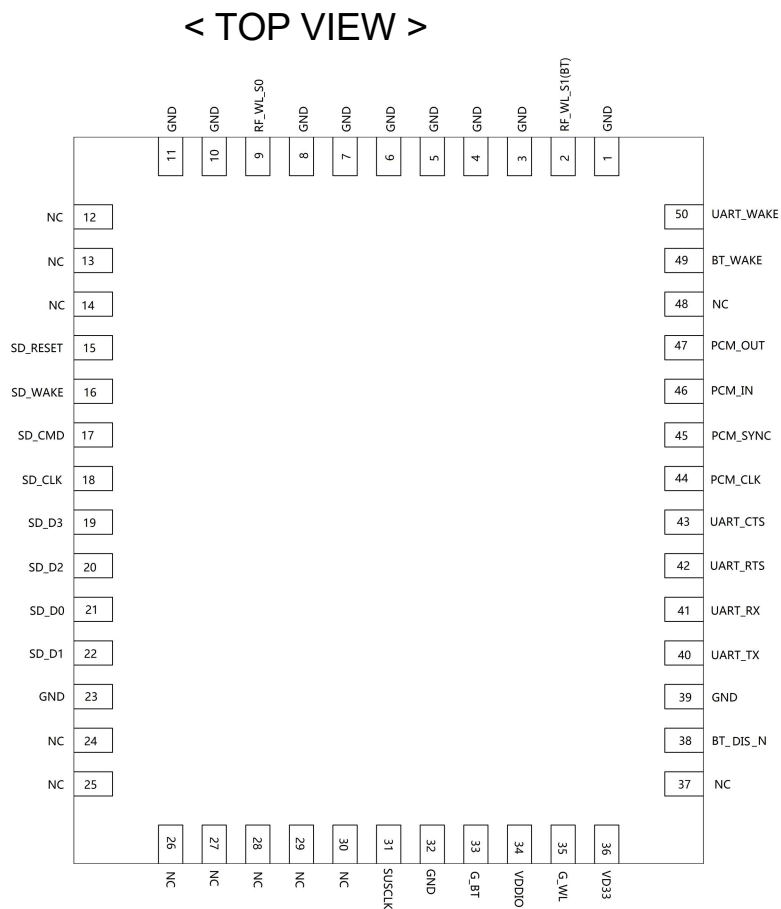

## 6.2 Pin Definition details

NO.	Name	Type	Description	Voltage
1	GND	—	Ground connections	
2	RF_S1	I/O	RF I/O port chain1, dual band Wi-Fi and BT (for 2ant type)	
3	GND	—	Ground connections	
4	GND	—	Ground connections	
5	GND	—	Ground connections	
6	GND	—	Ground connections	
7	GND	—	Ground connections	
8	GND	—	Ground connections	
9	RF_S0	I/O	RF I/O port chain0, dual band Wi-Fi	
10	GND	—	Ground connections	
11	GND	—	Ground connections	
12	NC	—	No connect	
13	NC	—	No connect	
14	NC	—	No connect	
15	SD_RESET	I/PU	Reset Pin for SDIO interface ON: pull high; OFF: pull low Low for disable SDIO interface	VDDIO
16	SD_WAKE	O	WLAN to wake-up HOST	VDDIO
17	SDIO_CMD	I/O	SDIO command line	VDDIO
18	SDIO_CLK	I/O	SDIO clock line	VDDIO
19	SDIO_D3	I/O	SDIO data line 3	VDDIO
20	SDIO_D2	I/O	SDIO data line 2	VDDIO
21	SDIO_D0	I/O	SDIO data line 0	VDDIO
22	SDIO_D1	I/O	SDIO data line 1	VDDIO
23	GND	—	Ground connections	
24	NC	—	No connect	
25	NC	—	No connect	
26	NC	—	No connect	
27	GND	—	Ground connections	
28	NC	—	No connect	
29	NC	—	No connect	
30	GND	—	Ground connections	

31	SUSCLK	I/PD	External Low Power Clock input (32.768KHz) If not used keep NC	
32	GND	—	Ground connections	
33	G_BT	I/O/PD	GPIO5 If not used keep NC.	
34	VDDIO	P	I/O Voltage supply input 1.8V or 3.3V	1.8V or 3.3V
35	G_WL	I/O/PD	GPIO4, G_WL If not used keep NC. Do not pull high on this pin.	
36	VD33	P	Main power voltage source input 3.3V	3.3V
37	NC	—	No connect	
38	BT_DIS_N	I/PU	Enable pin for Bluetooth device ON: pull high; OFF: pull low External pull low to shut down BT, but when module in initial step do not pull low.	VDDIO
39	GND	—	Ground connections	
40	UART_TX	O	Bluetooth UART interface	VDDIO
41	UART_RX	I	Bluetooth UART interface	VDDIO
42	UART_RTS	O	Bluetooth UART interface	VDDIO
43	UART_CTS	I	Bluetooth UART interface	VDDIO
44	PCM_CLK	I/O	PCM clock	VDDIO
45	PCM_SYNC	I/O	PCM sync signal	VDDIO
46	PCM_IN	I	PCM data input	VDDIO
47	PCM_OUT	O	PCM Data output	VDDIO
48	NC	—	No connect	
49	BT_WAKE	O	HOST wake-up BT device	VDDIO
50	UART_WAKE	O	BT device wake-up HOST	VDDIO

P:POWER I:INPUT O:OUTPUT VDDIO:3.3V

## 7. Electrical Specifications

### 7.1 Power Supply DC Characteristics

	Min.	Typ.	Max.	Unit
Operating Temperature	0	25	70	deg.C
VCC33	3.15	3.3	3.45	V
VDDIO (3.3V)	-	3.3	3.6	V
VDDIO (1.8V)	1.68	1.8	1.98	V

### 7.2 Interface Circuit time series

#### 7.2.1 Power on sequence

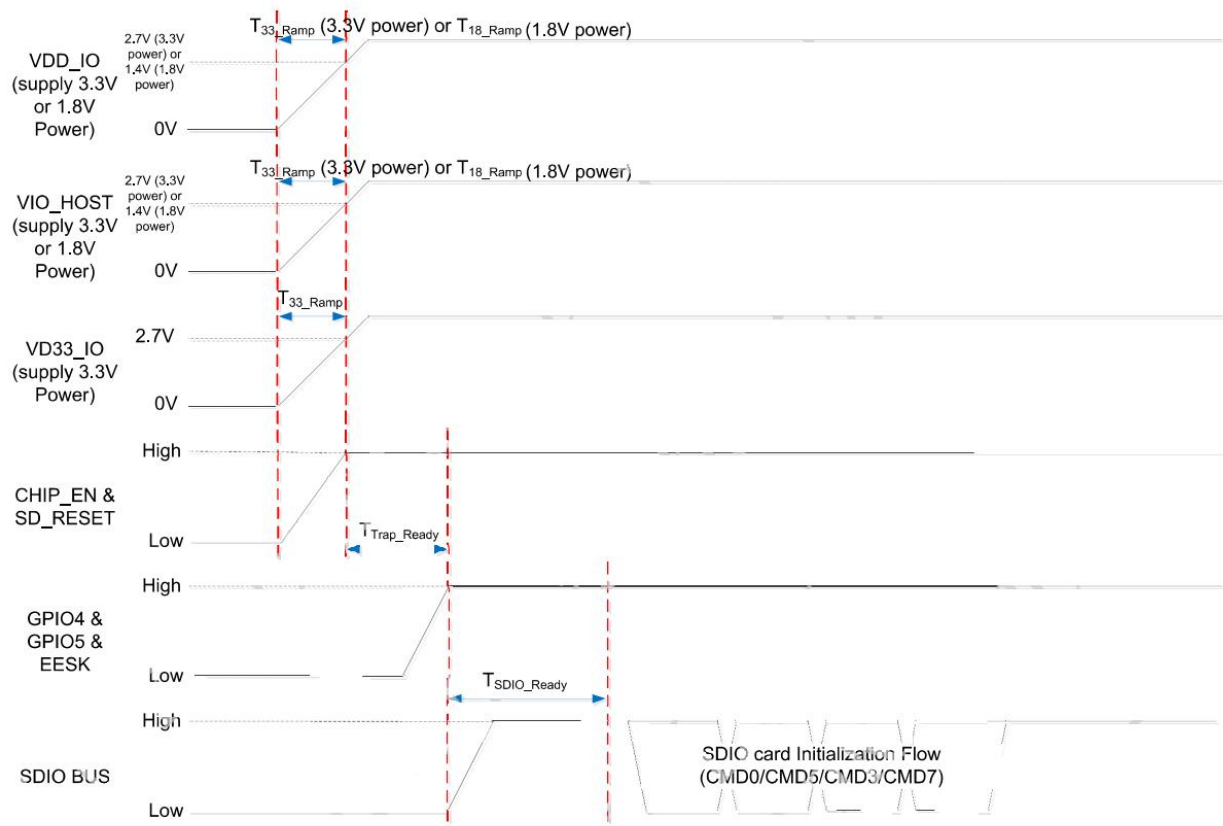

	<b>Min.</b>	<b>Typical</b>	<b>Max.</b>	<b>Unit</b>	<b>Description</b>
T18_Ramp	0.5	1.5	5	ms	The 1.8V power ramp up duration.
T33_Ramp	0.5	1.5	5	ms	The 3.3V power ramp up duration.
TTrap_Ready	400	500	X	ms	WLAN eFuse autoload. TTrap_Ready = 500ms (Typical)
TSDIO_Ready	10	20	X	ms	SDIO Not Ready Duration. In this state, the RTL8852BS may respond to commands without the ready bit being set. After the ready bit is set, the host will initiate complete card detection procedure.

### 7.2.2 SDIO Pin Description

The module supports SDIO version 3.0 for all 1.8V 4-bit in addition v2.0 to the 3.3V .

SDIO Pin Description

<b>SD 4-Bit Mode</b>	
DATA0	Data Line 0
DATA1	Data Line 1 or Interrupt
DATA2	Data Line 2 or Read Wait
DATA3	Data Line 3
CLK	Clock
CMD	Command Line

### 7.2.3 SDIO Timing Diagram

For timing criteria, please check specification in “SD specification Part1 Physical Layer Specification Version 3.01”

## 8. Size reference

### 8.1 Module Picture

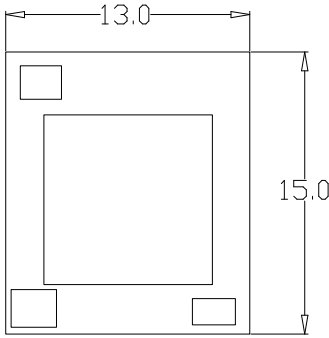
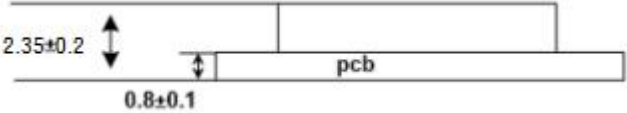
<p>L x W : 15 x 13 (+0.3/-0.1) mm</p>	
<p>H: 2.35 (±0.2) mm</p>	
<p><b>Weight</b></p>	<p>0.8g</p>

### 8.2 Marking Description



备注:

二维码内容: 112233445566;FG6252BASR-00

1. Fn-Link 商标 logo
2. 机型: 6252BA-SR
3. 二维码: 编码规则为 “wifi mac 地址;成品料号”

例如: 112233445566;FG6252BASR-00 (MAC 地址以实际为准)

----BT MAC 在 WIFI MAC 基础上+1 (WIFI地址需跳 1, 不能与 BT 地址重复), 二维码中不显示此内容。

4. V/N 00(V/N 到 00 之间为两个空格, 00 为成品料号尾缀, 与二维码右对齐)

### 8.3 Physical Dimensions

<TOP View>

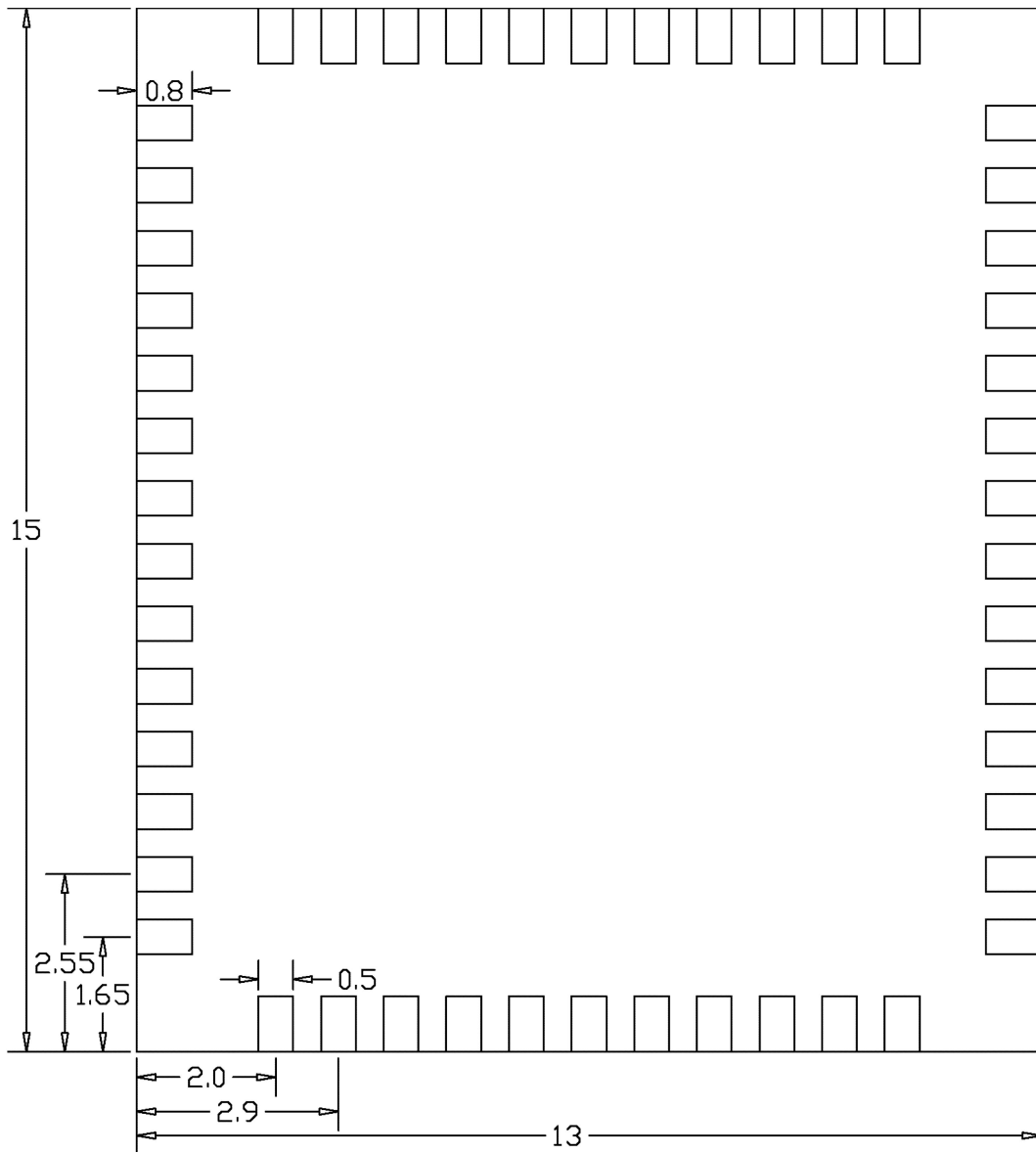

### 8.4 Layout Recommendation

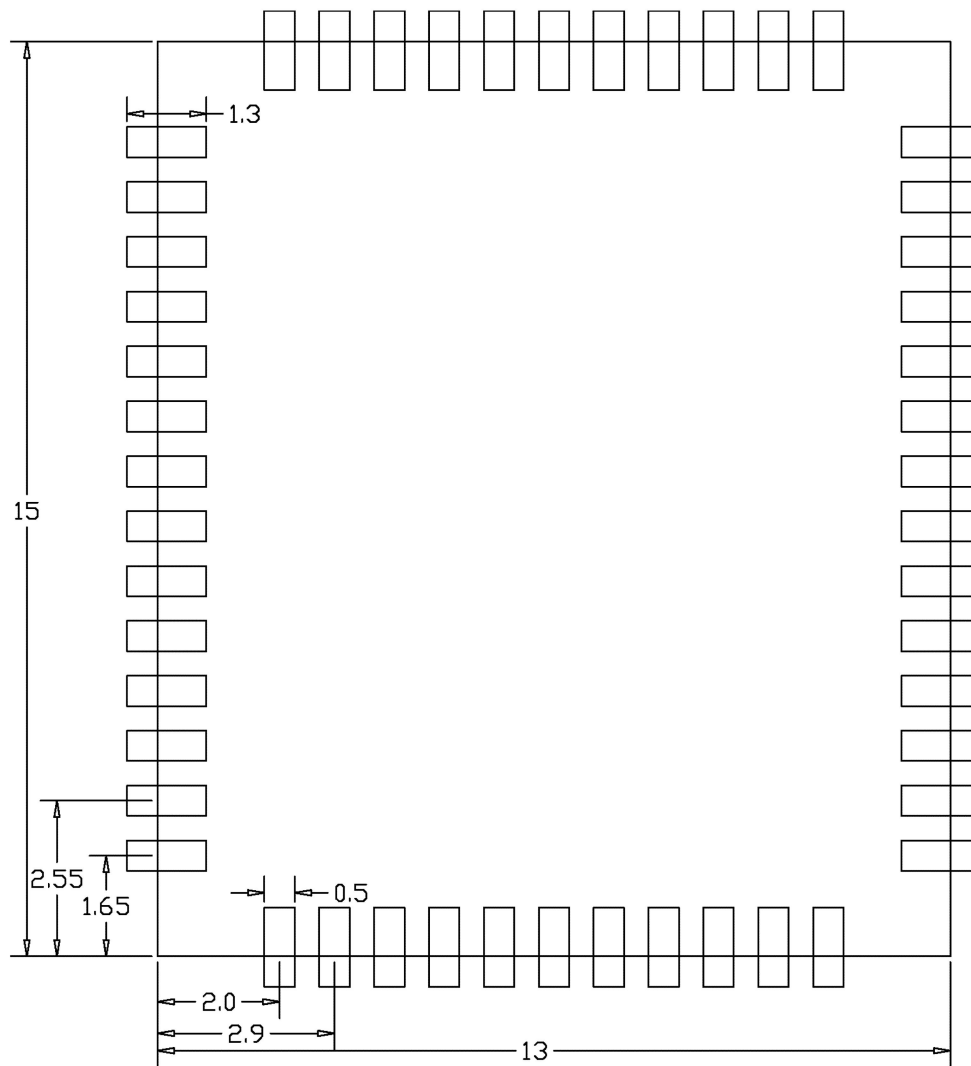

### 9. The Key Material List

Item	Part Name	Description	Manufacturer
1	PCB	6252BA-SR,4L,FR4,13×15-0.8mm	XY-PCB, GDKX, Sunlord, SLPCB, Truly
2	Crystal	2016 40MHz ±10ppm 12pF	ECEC, Hosonic, TKD, JWT
3	Chipset	RTL8852BS	Realtek
4	Shielding	6252BA-SR Shielding	信太, 精力通, 卓益
5	Inductor	0603 2.2uH, ±10%	Sunlord, Ceaiya, Cenker, Chilisin, Inpaq
6	Inductor	2016 1.0uH, ±20%	Sunlord, Ceaiya, Cenker, Chilisin, Inpaq



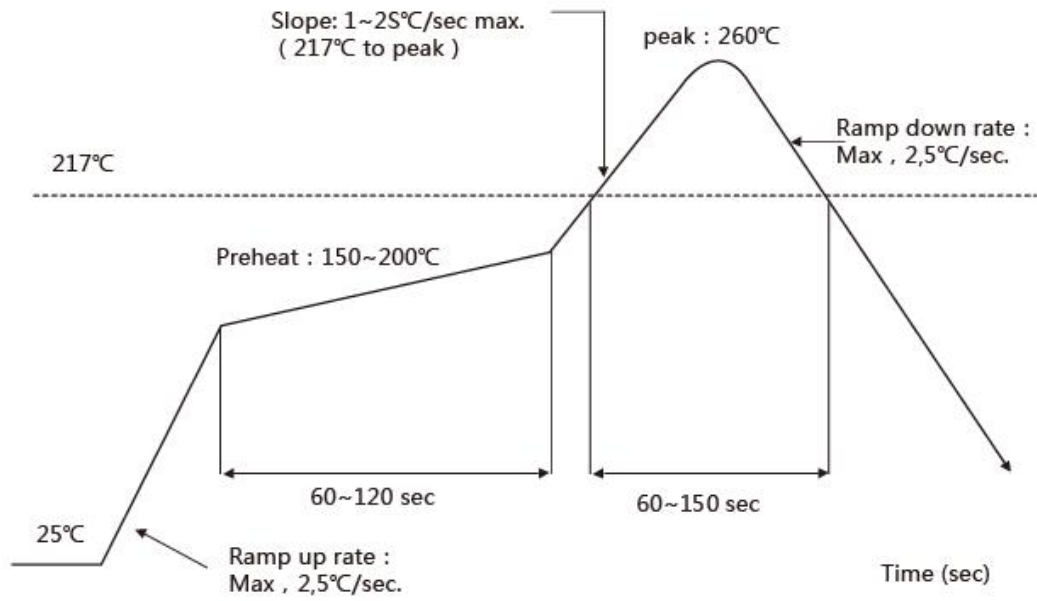

## 12. Package

### 12.1 Reel

A roll of 1500pcs

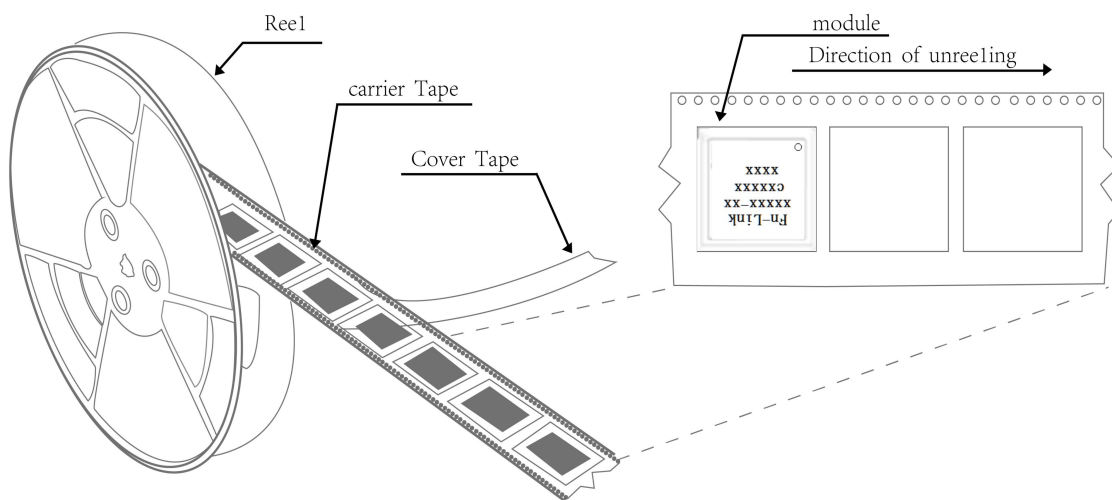

### 12.2 Carrier Tape Detail

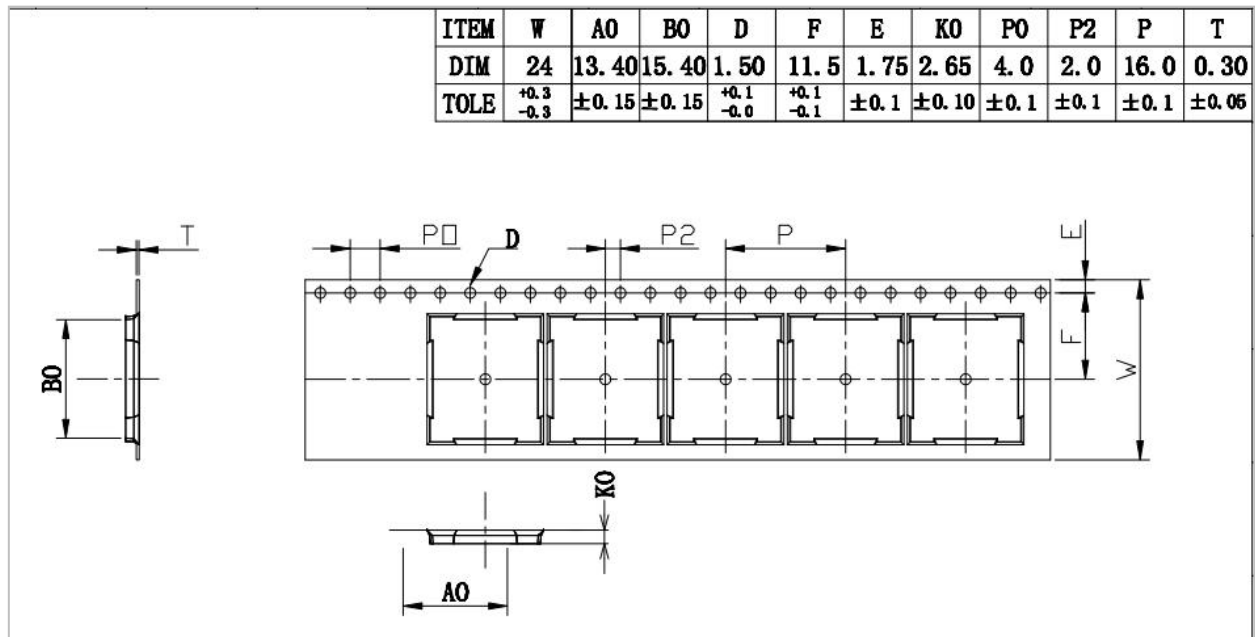

### 12.3 Packaging Detail

the take-up package

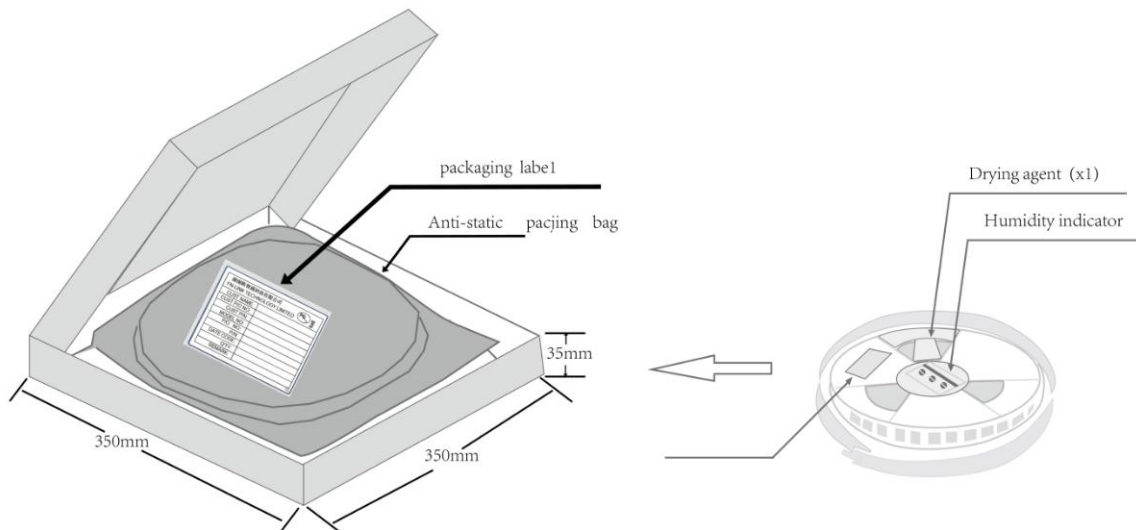

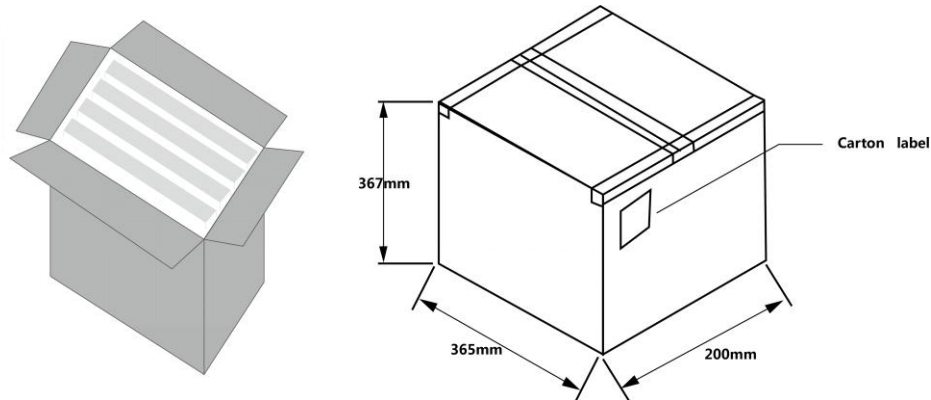

### 12.4 Tray

Use pallet packaging for less than 300 pieces

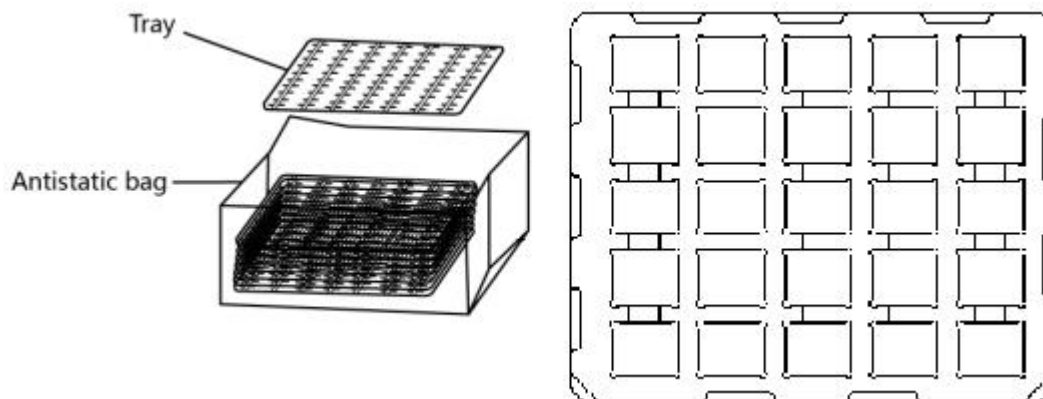

### 13. Moisture sensitivity

The Modules is a Moisture Sensitive Device level 3, in according with standard IPC/JEDEC J-STD-020, take care

all the relatives requirements for using this kind of components.

Moreover, the customer has to take care of the following conditions:

- a) Calculated shelf life in sealed bag: 12 months at <math><40^{\circ}\text{C}</math> and <math><90\%</math> relative humidity (RH).
- b) Environmental condition during the production: <math>30^{\circ}\text{C}</math> / <math>60\%</math> RH according to IPC/JEDEC J-STD-033A paragraph 5.
- c) The maximum time between the opening of the sealed bag and the reflow process must be 168 hours if condition

- b) “IPC/JEDEC J-STD-033A paragraph 5.2” is respected
- d) Baking is required if conditions b) or c) are not respected
- e) Baking is required if the humidity indicator inside the bag indicates 10% RH or more